

**Computer Controlled Servo-Hydraulic Universal Testing Machine  
Model WAW-1000C**

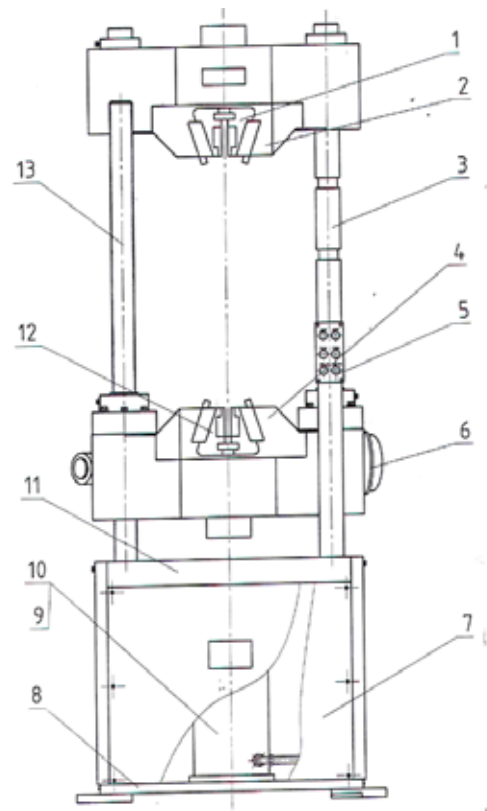
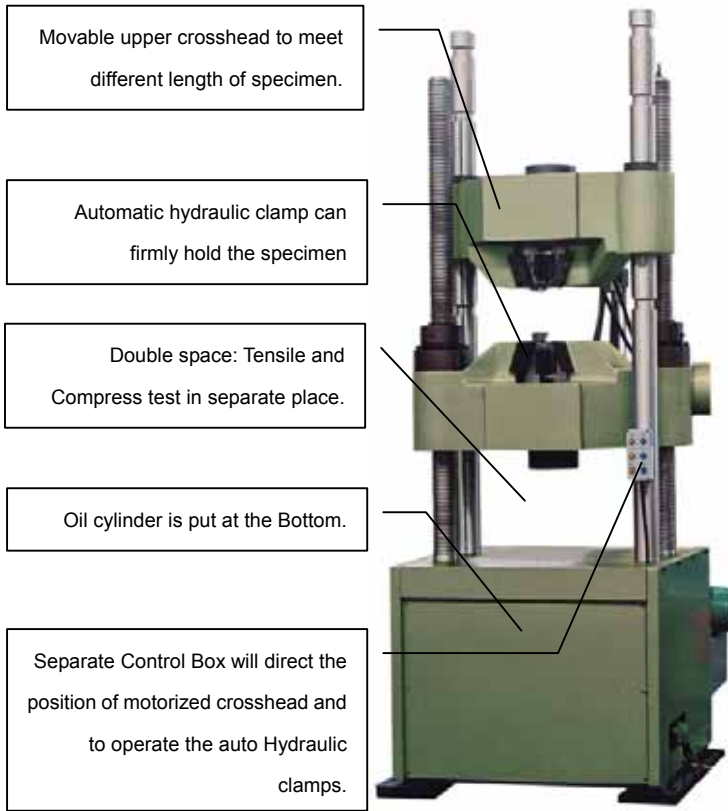

Servo-hydraulic Oil source Cabinet (Left) and Computer controlled system (Right) is providing Power operation of Complete system, Hydraulic motor of oil cylinder, Hydraulic Auto clamps, Emergency stop and Complete computer controlling of Testing Process, programming edit.

No.	Parts Name
1	Upper Clamps Pedestal
2	Upper Crosshead
3	Upper Crosshead Column
4	Lower (Movable) Crosshead
5	Control Box
6	Crosshead Motor
7	Base Cover
8	Base support
9	Oil Cylinder
10	Oil Piston
11	Platform (Compression Place)
12	Lower Clamps Pedestal
13	Screw Column for Movable Crosshead

**Specifications for WAW-1000C:**

- ▶ Max Load capacity: 1000kN
- ▶ Accuracy of test load: Better than 1%
- ▶ Thickness of specimen: 0-55mm
- ▶ Round specimen:  $\Phi$ 8mm-70mm
- ▶ Compression plate: 204 x 204 mm
- ▶ Crosshead velocity: 420mm/min MAX
- ▶ Dimension of load frame: 3020mm x 2200mm x 3370mm
- ▶ Conforming Standard: ISO7500-1999

**Features:**

1. Full computer controlled of testing process.
2. Adopt oil-hydraulic automatic clamps which can be operated from separate control box.
3. Powerful multifunctional control software will provide more testing methods.
4. Report Guide will create your testing report in only three steps.
5. Programable testing software, Make LCF testing become available.
6. Overload protection will secure operators.

**Testing Accessories:**

1. Clamping Grips:

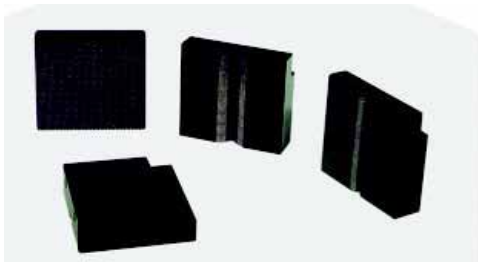

2. Compression Plates with its support

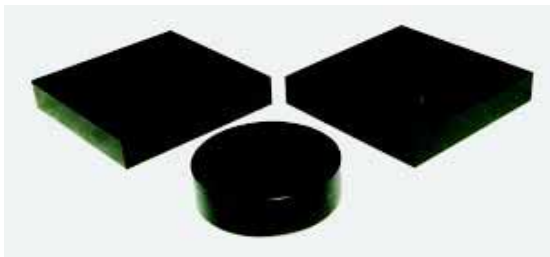

3. Bending Head and Bending Support



Standard Accessory for WAW-1000C					
Item	NO.	Name	Specification	Q'ty	Note
Accessories (mm)	1	Jaws for Flat Specimens	0-55mm	1 set	
	2	Jaws for Round Specimens	Φ8mm-70mm	1 set	
	3	Bending Support	60~65HRC	1 set	
	4	Bending Compression Head	60~65HRC	1 set	
	5	Spherical seat Plate	Φ100	1 set	
	6	Lower Compression Plate	204 x 204 mm	1 set	
	7	Upper Compression Plate	204 x 204 mm	1 set	
	8	Anchor Nuts & Bolts	M16	1 set	
	9	Extensometer		1 set	
Tool	1	Inner-hexagon Spanner	Opposite edge × L 5×85 6×90 10×115 12×125	1 set	
	2	Tool Hook	Φ4×225	1 pce	
	3	Threaded Rod	M5×100 M10×120	2 pcs	
Spares	1	Gasket	Φ24×2	1 pcs	
	2	Aluminum gasket		1 pcs	
	3	Connect oil pipe			
Special Accessories	1	Shearing attachment		1 pcs	

**Guarantee: 01 year**